

BOCA BEACH CLUB REPLAT OF PARCEL "A"

BEING A REPLAT OF PARCEL "A", BOCA BEACH CLUB, AS RECORDED IN PLAT BOOK 67, PAGES 148-150, PALM BEACH COUNTY RECORDS LYING IN SECTIONS 28 AND 29, TOWNSHIP 47 SOUTH, RANGE 43 EAST CITY OF BOCA RATON, PALM BEACH COUNTY, FLORIDA

38

STATE OF FLORIDA
COUNTY OF PALM BEACH
This plat was filed for record on this _____ day of _____, 2009, and duly recorded in Plat Book _____, Pages _____, through _____
By: _____

THIS INSTRUMENT WAS PREPARED BY:
MARISHA M. KREITMAN, P.S.M.
AVROM & ASSOCIATES, INC.
SURVEYING & MAPPING
50 S.W. 2nd AVENUE, SUITE 102
BOCA RATON, FLORIDA 33432
(561) 392-2594
JUNE, 2009

SHEET 4 OF 8

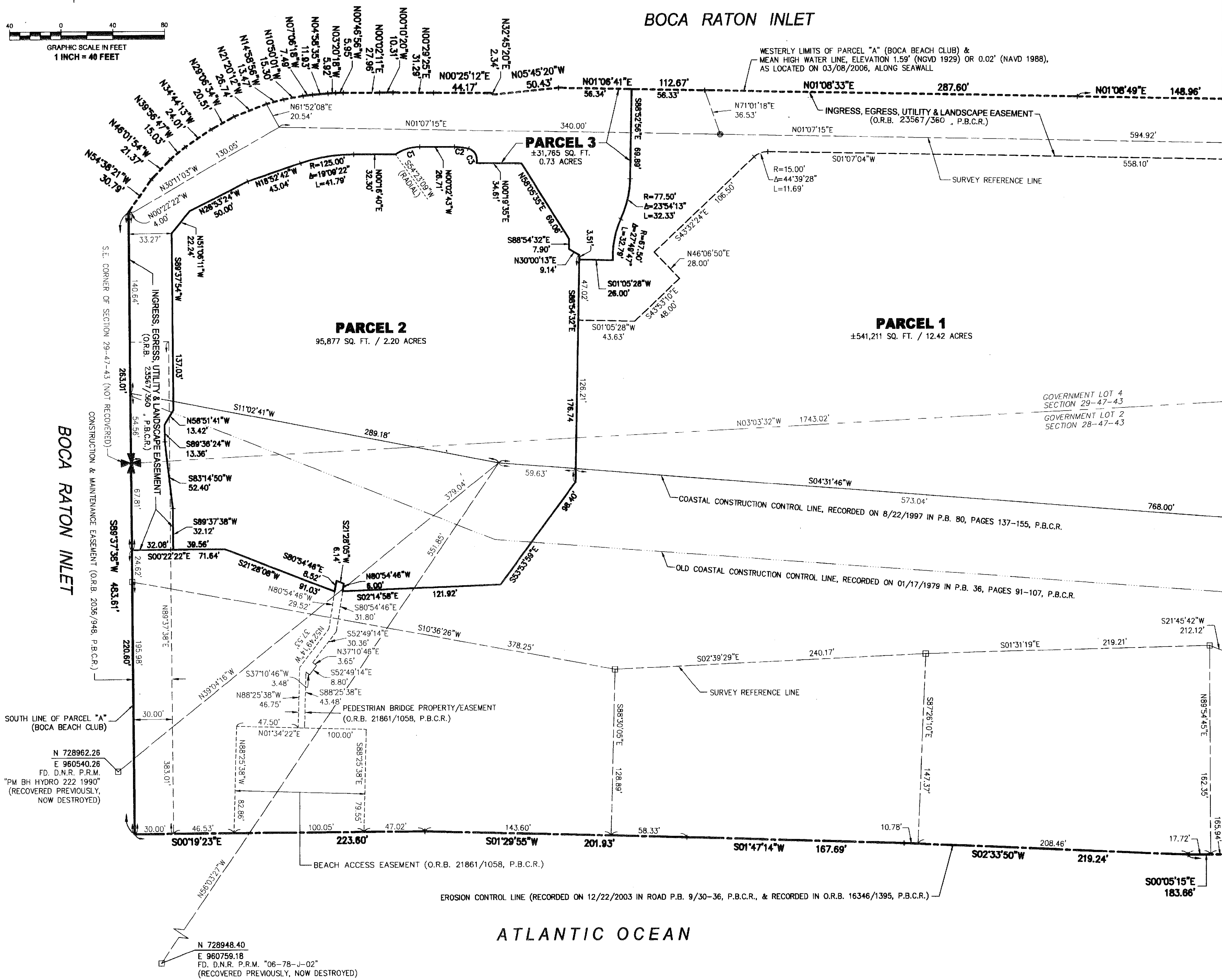
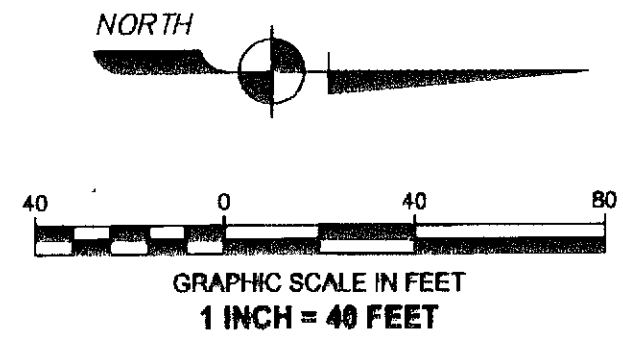

AREA TABULATION

PARCEL	SQ. FT.	ACRES
PARCEL 1	±541,211	±12.42
PARCEL 2	95,877	2.20
PARCEL 3	±31,765	±0.73
PARCEL 4	20,291	0.47
PARCEL 5	4,743	0.11
TOTAL	±693,887	±15.93

CURVE TABLE

CURVE	RADIUS	DELTA ANGLE	LENGTH
C1	32.30	35°34'08"	20.05
C2	37.30	16°38'06"	10.83
C3	9.30	89°23'22"	14.51

NOTICE:

THIS PLAT, AS RECORDED IN ITS GRAPHIC FORM, IS THE OFFICIAL DEPICTION OF THE SUBDIVIDED LANDS DESCRIBED HEREIN AND WILL IN NO CIRCUMSTANCES BE SUPPLANTED IN AUTHORITY BY ANY OTHER GRAPHIC OR DIGITAL FORM OF THE PLAT. THERE MAY BE ADDITIONAL RESTRICTIONS THAT ARE NOT RECORDED ON THIS PLAT THAT MAY BE FOUND IN THE PUBLIC RECORDS OF THIS COUNTY.

NOTE:

SEE SHEET 5 OF 8 FOR DETAILS ON ADDITIONAL EASEMENTS
SEE SHEET 6 OF 8 FOR DETAILS ON FLORIDA POWER & LIGHT COMPANY EASEMENTS
SEE SHEET 7 OF 8 FOR DETAIL OF SEWER EASEMENT DEDICATED BY THIS PLAT
SEE SHEET 8 OF 8 FOR DETAIL OF WATER EASEMENT DEDICATED BY THIS PLAT

NOTES:

- THERE SHALL BE NO BUILDINGS OR ANY KIND OF CONSTRUCTION, PLACED ON UTILITY OR DRAINAGE EASEMENTS, EXCEPT DRIVEWAYS AND/OR SIDEWALKS.
- THERE SHALL BE NO TREES OR SHRUBS, PLACED ON UTILITY EASEMENTS, LANDSCAPING ON OTHER UTILITY EASEMENTS SHALL BE ALLOWED ONLY AFTER CONSENT OF ALL UTILITY COMPANIES HAVING THE RIGHT TO OCCUPY THE SAME.
- IN INSTANCE WHERE DRAINAGE AND UTILITY EASEMENTS INTERSECT, CONSTRUCTION, OPERATION, AND MAINTENANCE OF DRAINAGE WITHIN THESE AREA OF INTERSECTION SHALL NOT INTERFERE WITH THE CONSTRUCTION, OPERATION, AND MAINTENANCE OF UTILITY FACILITIES.
- BUILDING SETBACK LINES SHALL BE AS REQUIRED BY CURRENT CITY OF BOCA RATON ZONING REGULATIONS.
- BEARINGS SHOWN HEREON ARE RELATIVE TO THE COASTAL CONSTRUCTION CONTROL LINE AS RECORDED IN PLAT BOOK 80, PAGES 137 THROUGH 155 OF THE PUBLIC RECORDS OF PALM BEACH COUNTY, FLORIDA WITH THE NORTH LINE OF PARCEL "A", BOCA BEACH CLUB, HAVING A BEARING OF S86°22'32"E.
- COORDINATES SHOWN HEREON ARE BASED UPON THE STATE PLANE COORDINATE SYSTEM, FLORIDA EAST ZONE NORTH AMERICAN DATUM OF 1983 (NAD 83), 1990 ADJUSTMENT, AS SHOWN ON PLAT BOOK 80, PAGES 137 THROUGH 155, OF THE PUBLIC RECORDS OF PALM BEACH COUNTY, FLORIDA.
- DIMENSIONS SHOWN HEREON ARE IN FEET AND DECIMAL PARTS THEREOF AND ARE BASED ON THE DEFINITION OF FOOT AS ADOPTED BY THE UNITED STATES BUREAU OF STANDARDS AND REFER TO THE HORIZONTAL PLANE.
- BENCHMARK DESCRIPTION: U.S. COAST AND GEODETIC SURVEY BENCHMARK #E 312 - FOUND A U.S. COAST & GEODETIC SURVEY BRASS DISC STAMPED "E 312 1970", ELEVATION = 5.37 FEET (NGVD 1929) OR 3.80 FEET (NAVD 1988).
- ELEVATIONS INDICATED HEREON ARE IN FEET AND DECIMAL PARTS THEREOF REFERENCED TO THE NATIONAL GEODETIC VERTICAL DATUM OF 1929 (NGVD 1929) AND CONVERTED TO THE NORTH AMERICAN VERTICAL DATUM OF 1988 (NAVD 1988). DATUM CONVERSION WAS DONE UTILIZING THE U.S. ARMY CORPS OF ENGINEERS PROGRAM CORPSPCON FOR WINDOWS, VERSION 5.11.08. THE MODEL VALUE OF (-) 1.57 WAS ADDED ALGEBRAICALLY TO THE NGVD 1929 HEIGHT.
- INDICATES SET PERMANENT REFERENCE MONUMENT (P.R.M.) - 4"x4"x24" CONCRETE MONUMENT WITH BRASS DISK STAMPED "P.R.M. L.B. 3300", UNLESS OTHERWISE NOTED.
- INDICATES SET PERMANENT REFERENCE MONUMENT (P.R.M.) - NAL & BRASS DISK STAMPED "P.R.M. L.B. 3300", UNLESS OTHERWISE NOTED.
- ABBREVIATION LEGEND: C = CENTERLINE; D.B. = DEED BOOK; D.N.R. = DEPARTMENT OF NATURAL RESOURCES; Δ = CENTRAL ANGLE; FD. = FOUND; F.D.O.T. = FLORIDA DEPARTMENT OF TRANSPORTATION; F.P.L. = FLORIDA POWER & LIGHT COMPANY; L = ARC LENGTH; L.B. = LICENSED BUSINESS; NAVD = NORTH AMERICAN VERTICAL DATUM; NGVD = NATIONAL GEODETIC VERTICAL DATUM; O.R.B. = OFFICIAL RECORDS BOOK; P.B. = PLAT BOOK; P.B.C.R. = PALM BEACH COUNTY RECORDS; PGS. = PAGES; P.R.M. = PERMANENT REFERENCE MONUMENT; P.L.S. = PROFESSIONAL LAND SURVEYOR; P.S.M. = PROFESSIONAL SURVEYOR & MAPPER; R = RADIUS; R/W = RIGHT-OF-WAY; SQ. FT. = SQUARE FEET; S.R. = STATE ROAD; U.E. = UTILITY EASEMENT.

MATCH LINE (SEE SHEET 3 OF 8)